

TB206 LR501, RF out/Gain vs RF in, Vds=28Vdc, Idq=0.8A, Freq=160MHz

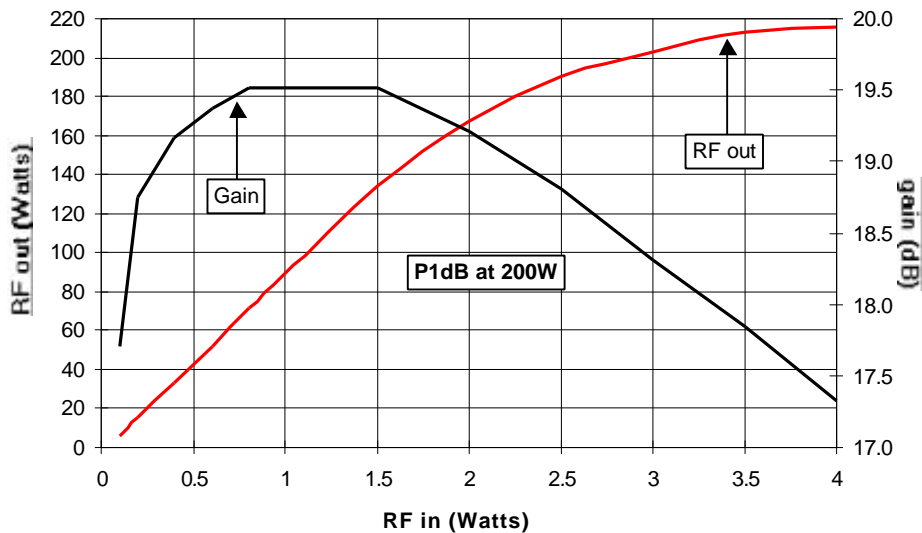

TB206 LR501, RF out/Gain vs RF in, Vds=28Vdc, Idq=0.8A, Freq=230MHz

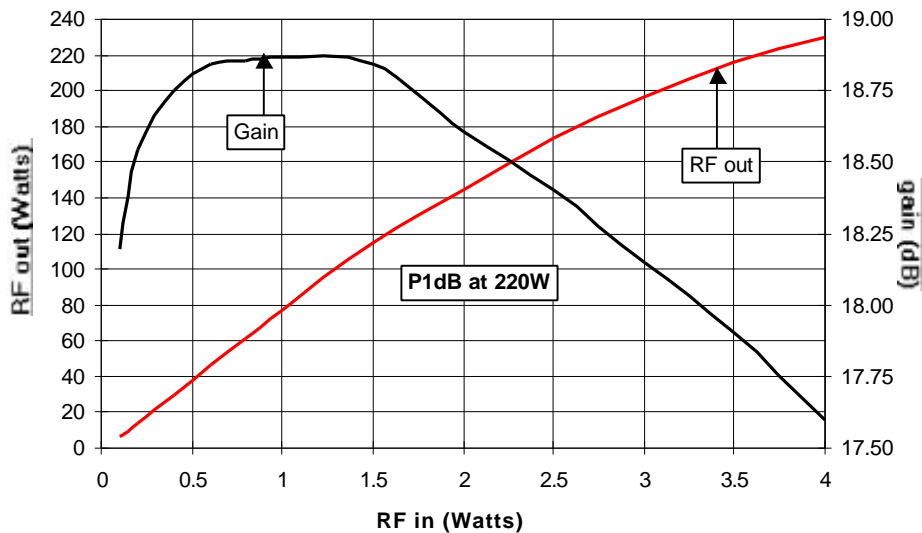

TB206 LR501, RF out/Gain vs RF in, Vds=28Vdc, Idq=0.8A, Freq=160-230MHz

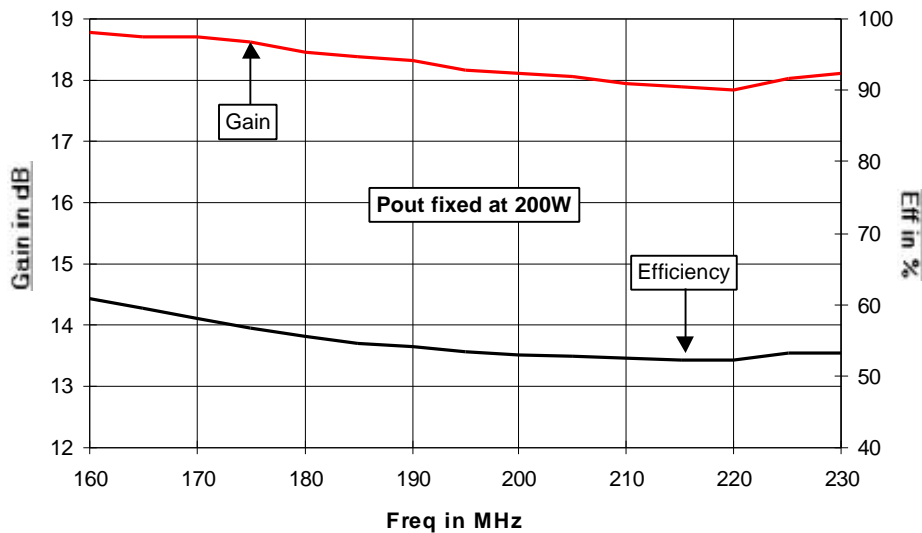

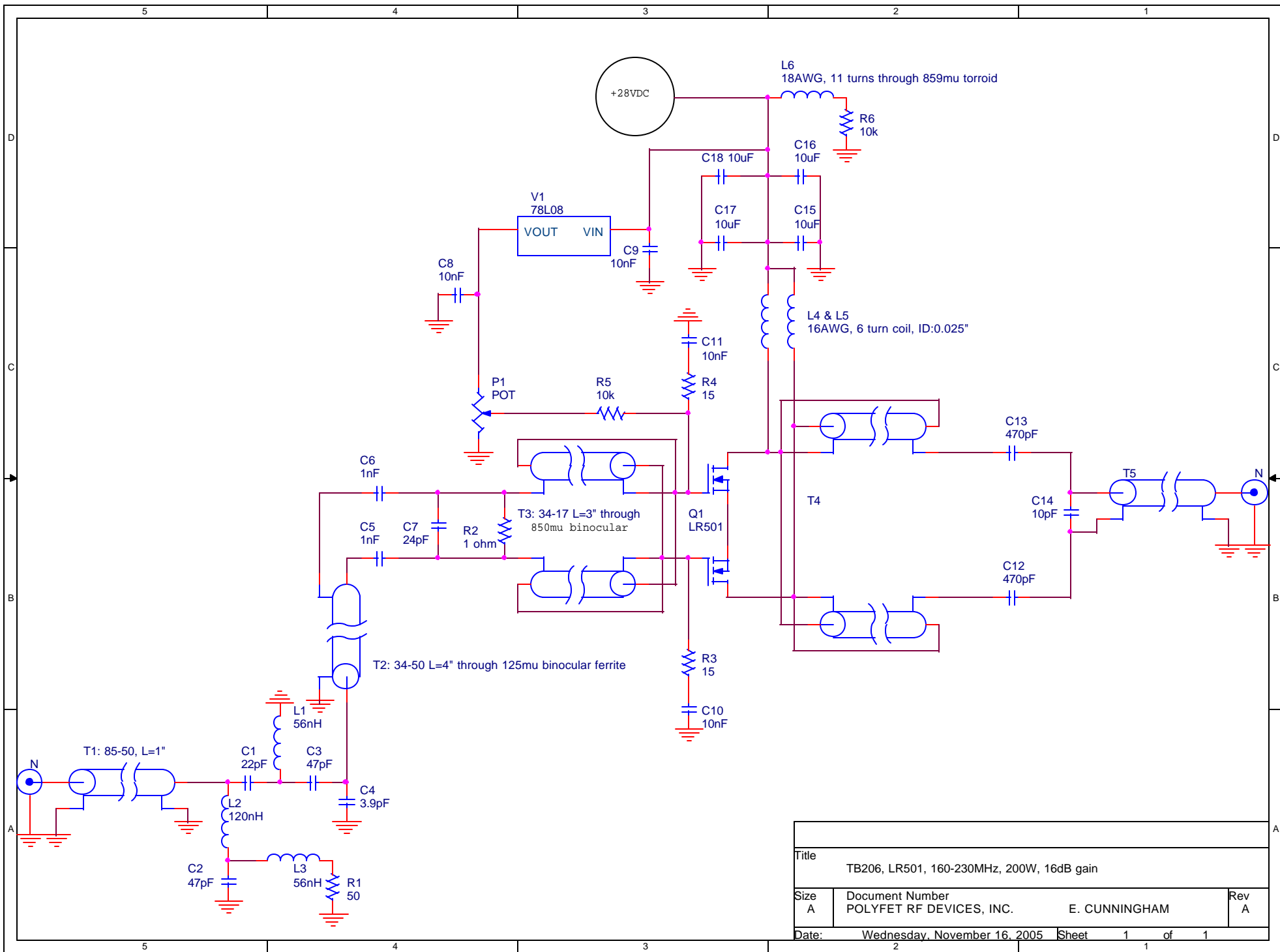

Title			
TB206, LR501, 160-230MHz, 200W, 16dB gain			
Size	Document Number	E. CUNNINGHAM	Rev
A	POLYFET RF DEVICES, INC.		A
Date:	Wednesday, November 16, 2005	Sheet	1 of 1

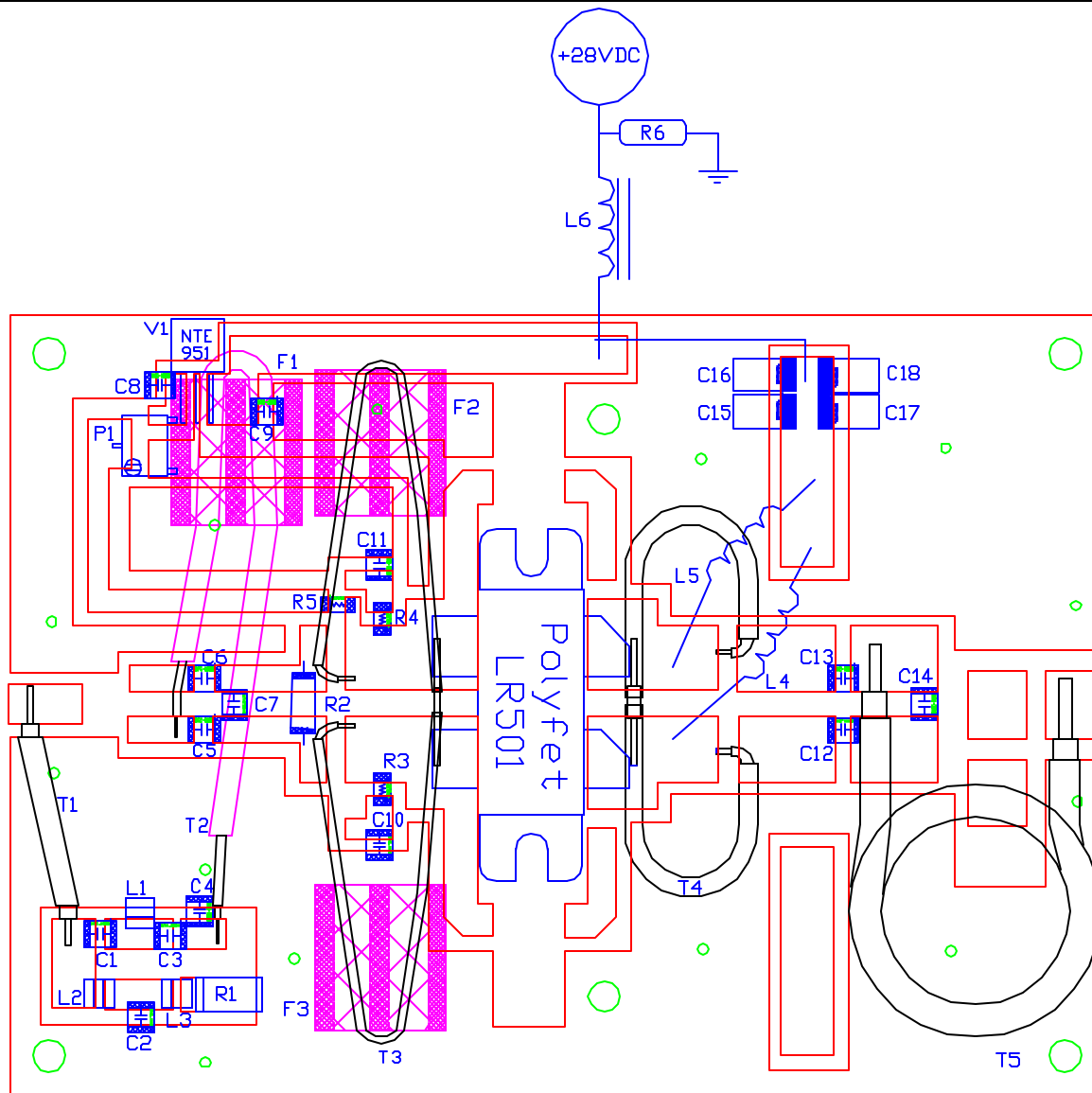

SYMBOL	VALUE	DESCRIPTION
C1	22pF	ACT100B Chip Cap.
C2, C3	47pF	ACT100B Chip Cap.
C4	3.9pF	ACT100B Chip Cap.
C5, C6	1nF	ACT700B Chip Cap.
C7	24pF	ACT100B Chip Cap.
C8, C9, C10, C11	10nF	ACT200B Chip Cap.
C12, C13	470pF	ACT700B Chip Cap.
C14	10pF	ACT100B Chip Cap.
C15-C18	10uF	50V TANTALUM
R1	49.9	2512, 1%, 1W
R2	1	1W AXIAL
R3, R4	15	1206, 5%, 1/4W
R5	10K	1206, 5%, 1/4W
R6	10K	1/4W AXIAL
P01	10k	6x6mm Potentiometer
L1, L3	56nH	100BHT-36NTGLB, COILCRAFT
L2	120nH	100BHT-R12TGLB, COILCRAFT
L4, L5	16AWG	6-TURN, ID0.25"
L6	18AWG	11 TURNS, 850u torroid
T1	1'	85-50 COAX
T2	4'	34-50 MICRO-COAX
T3	3'	34-17 MICRO-COAX
T4	3'	70-10 COAX
T5	9'	141-50 COAX
F1	125u	2N-61-202 Aridon
F2, F3	850u	2N-43-202 Aridon
V1	BV	Regulator 78L08
VDD	28Vdc	DC Power Supply
Bias	0.8A	Bias for LR501

Double sided 2oz. Cu .064in
Er=4 FR4 material

* note, R2 leads were coiled to preserve lead inductance.

DRN BY: E Cunningham	11/16/05	POLYFET RF DEVICES	
CHKD: E Cunningham	11/16/05	TB206 160-230Mhz 200W 16dB	
ELECT: E Cunningham	11/16/05	SIZE	FSCM NO
MECH: E Cunningham	11/16/05	LR501 28Vdc, 0.8A	
PRDC:		REV A	
QUAL:		SCALE: 1:1	
PGMS:		SHEET 1 OF 1	

