

PCB Material : Double Side Teflon
 $\epsilon_r=2.5$, $H=0.032$, 1oz

SYMBOL	VALUE	DESCRIPTION
C1,C2	18pF	ATC-100B Chip Cap.
C3	3pF	ATC-100B Chip Cap.
C4	5.6pF	ATC-100B Chip Cap.
C5	9.1pF	ATC-100B Chip Cap.
C6	7.5pF	ATC-100B Chip Cap.
C7	2pF	ATC-100B Chip Cap.
C8	6.2pF	ATC-100B Chip Cap.
C9,C10	30pF	ATC-100B Chip Cap.
C11	1nF	ATC-200B Chip Cap.
C12-C18	10nF	ATC-200B Chip Cap.
C19	47uF	50V electrolytic
C20	0.7pF	ATC-100B Chip Cap.
D1,D2	7.5V	Zener Diode
F1-F3	850m μ I	Amidon BN-43-2402
F4	850m μ I	Amidon BN-43-202
J1,J2	50 Ohm	SMA Female
L1	22AVG	10 turns, 850m μ I
L2,L3	22AVG	20 turns .075in dia
R1, R2	22k Ohm	1206 Resistor
R3,R6,R7	10k Ohm	1206 Resistor
R4,R5	100 Ohm	Axial Resistor 1W
R8,R9	10k Ohm	6mm, multi-turn POT
T1,T2	50 Ohm	UT34-50, L=3"
W1	---	#18AVG Jumper
Vds	28V	Drain Voltage
Iddq	800mA	Bias Current

DRN BY: J.Citrolo	2/8/05
CHKD : T.Chang	01/10/06
ELECT :	
MECH :	
PRDC :	
QUAL :	
PQMS :	

POLYFET RF DEVICES	
30-1000MHz 15WP1dB 11dB gain	
SIZE	FSCM ND
TB198	LQ801
REV	1
SCALE :	SHEET 1 OF 1

29 Jan 2005 17:28:05

CH1 S11 LOG 10 dB/REF 0 dB
CH2 S21 LOG 10 dB/REF 0 dB

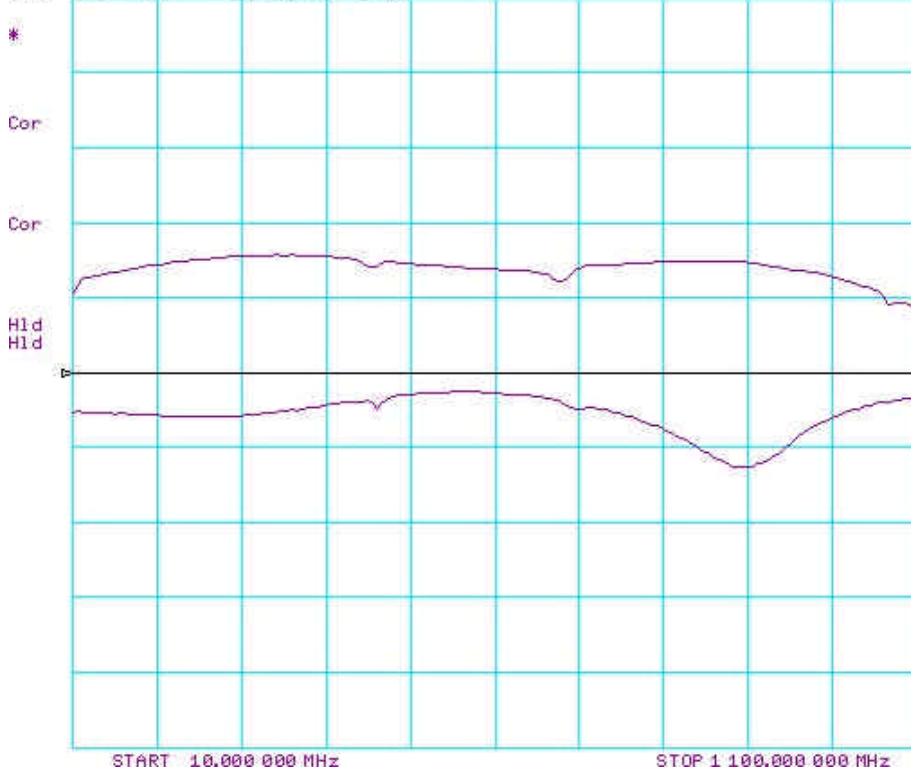

This is a small signal plot of the TB198 with a LQ801 running at 28Vdc and 800ma.

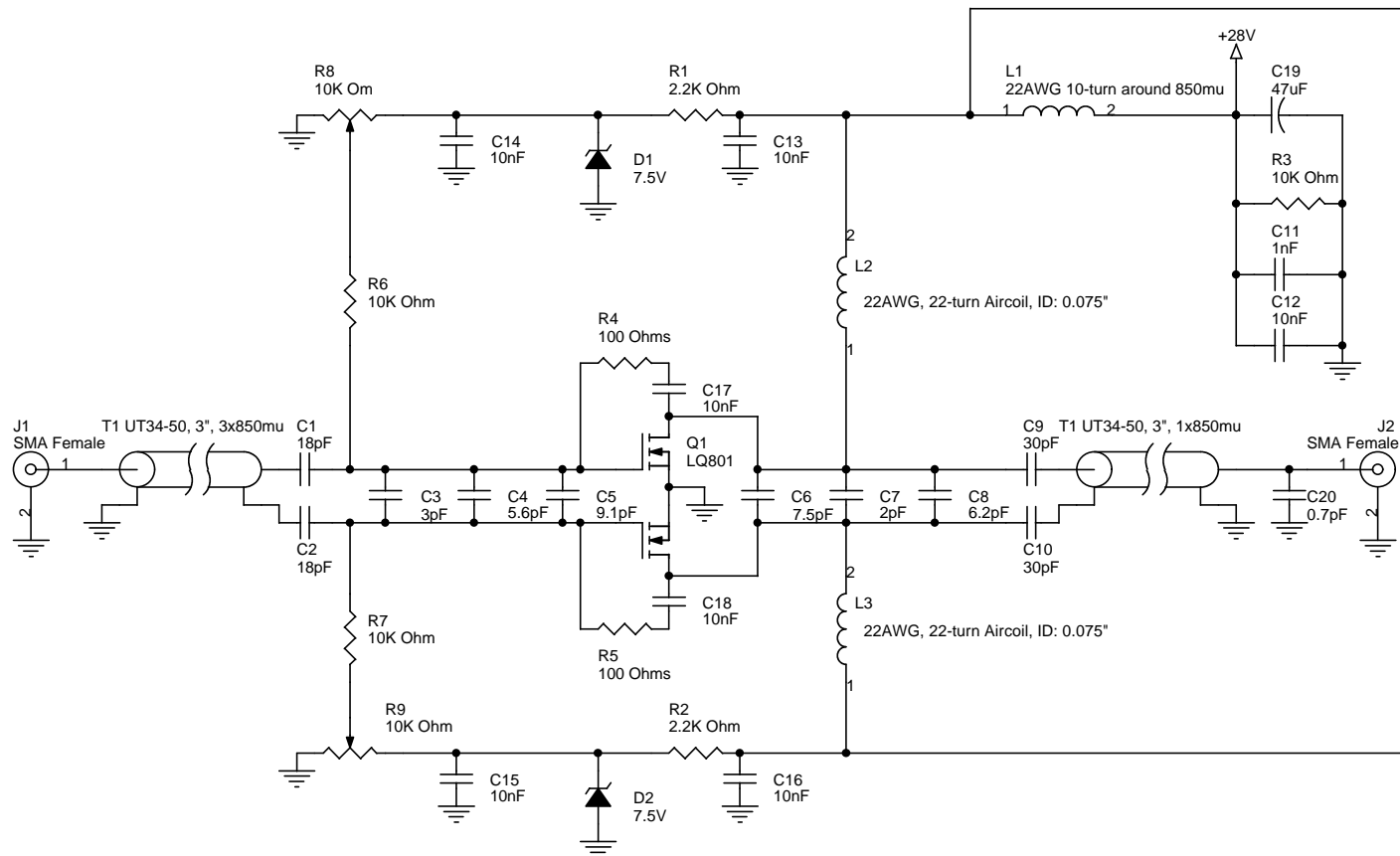

Title		
TB198 30-1000MHz, 15W P1dB, 11dB Gain		
Size	Document Number	Rev
	LQ801 Vds=28V Idq=800mA	0
Date:	Wednesday, January 11, 2006	Sheet 1 of 1