

DRN BY	J. Citrolo	11/18/02
CHKD		
ELECT		
MECH		
PROC		
QUAL		
PGMS		

Polyfet RF Devices	
TB 176 30-174Mhz 120W P1dB	
SIZE	FSCM NO.
	SR401 Vds=28Vdc Idq=1.6A
	REV

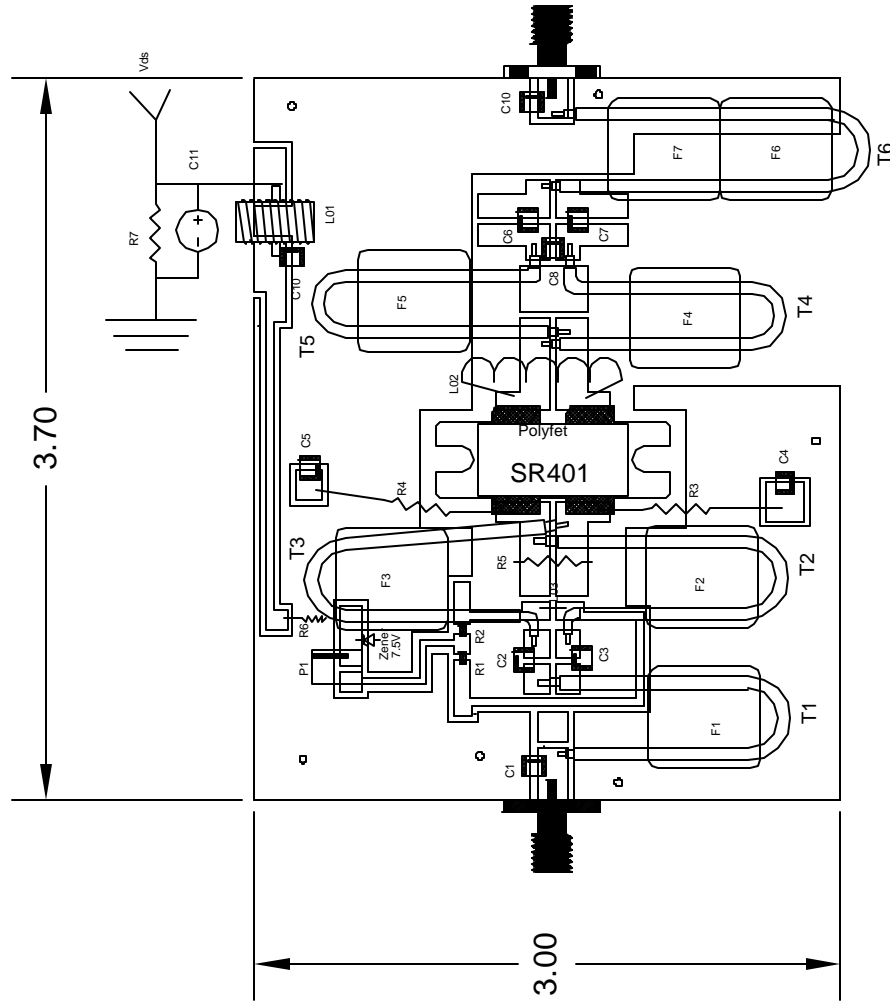

F1-F6= AMIDON BN-61-202 125mu BINOCULAR FERRITE

T1: UT85-50, 3.5 in.

T2-T3: UT75-10 3.5 in.

T4-T5: UT85-15 3.5 in.

T6: UT85-50 4in.

*Cut hole through pcb and epoxied F04-07 to copper using resinlab, ellsworth adhesives

C01	ATC-100B 11pf
C02-03	ATC-100B 39nf
C04,05,06,07	ATC-700B 1.2nf
C08	ATC-100B 11pf
C09	ATC-100B 8.2pf
C10	ATC-200B 39nf
C11	63uf,47V elec.
R01-02	0805 CHIP RES.- 10K
R03-04	1/4W 15 ohms
R05	5W 12ohms
R06	1/4W 2.2K ohms
R07	1/4W 10K ohms
L01	Toroid 850mu 18 awg, 14 turns
L02	9 turns, 18awg
L03	hair pin
P01	10K pot
F01-07	125mu Binocular
T01	UT85-50
T02-03	UT75-10
T04-05	UT85-15
T06	UT85-50
PCB	FR4, Et=3.55 0.064in. thick

DRNBY	Noah Xiang	11/20/02
MODBY:		
ELECT		
MECH	J Citrolo	
PROC		
QJAL		
MODBY:		
POLYFET RF DEVICES		
TB176 30-174MHZ, 120w P1dB, 50W LINEAR		
SIZE	FSCM.NO.	REV
	SR401 VDS=28VDC IDQ=1.6A	
SCALE: pcb 1:1		SHEET 1 OF 1

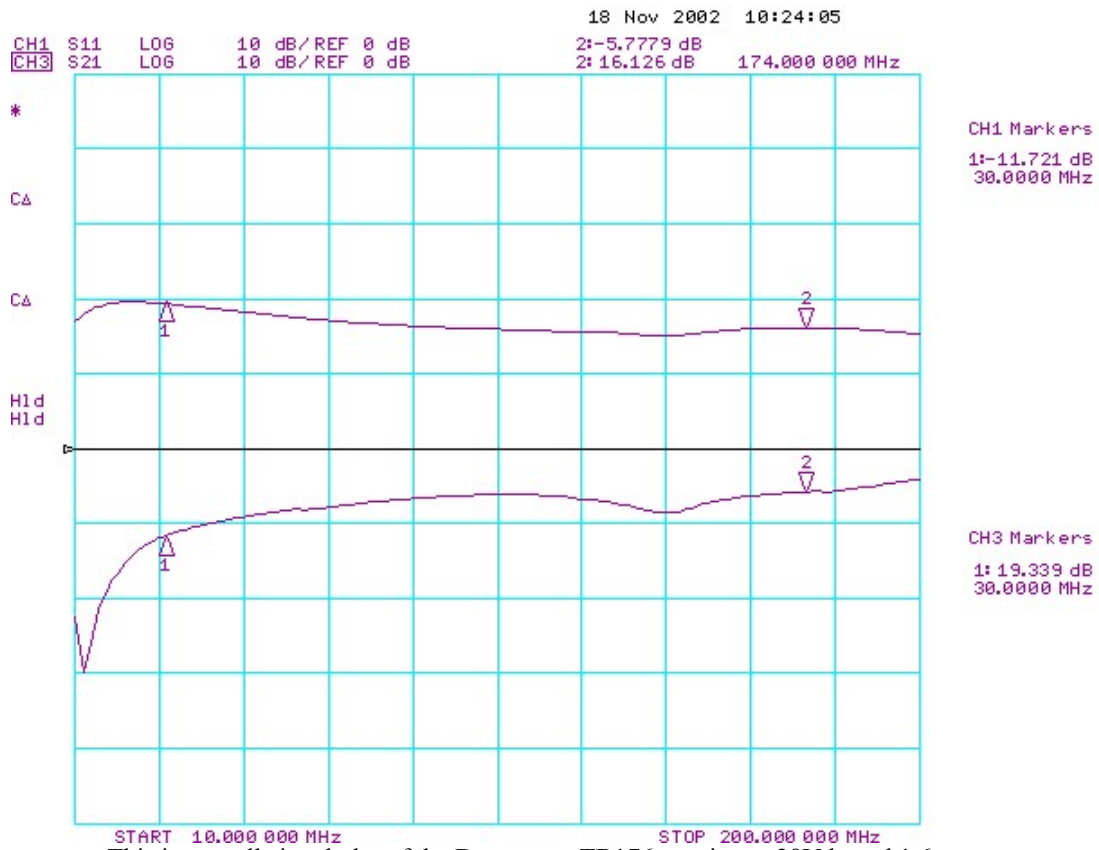

This is a small signal plot of the Demo amp TB176 running at 28Vdc and 1.6 amps.

