



**Power RF Amplifiers**

**Power = 15.0 Watts**

**Bandwidth = 30 to 512 Mhz**

**Gain = 25.0 dB    Vdd =28.0 Volts**

**50 ohms Input/Output Impedance**

**Description**

The MGDQ01 is a 15 Watt, 2 stage high gain amplifier covering a bandwidth of 30-512 Mhz using SMA connectors for RF in and out. This module is suitable for military applications in a rugged environment. An ALC pin is provided to control the output power of the module. The MGDQ01 may be used as the driver stage for the MBDQ01 module.

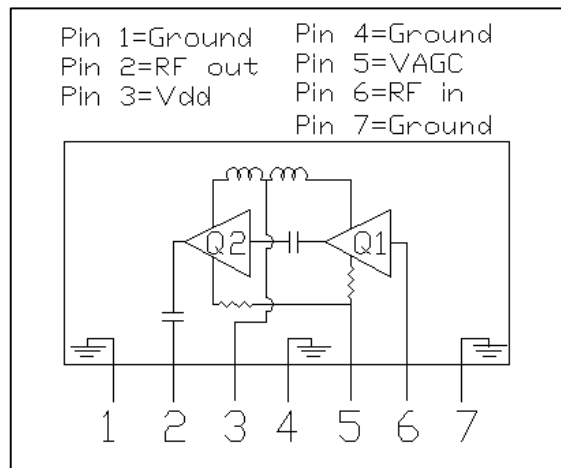
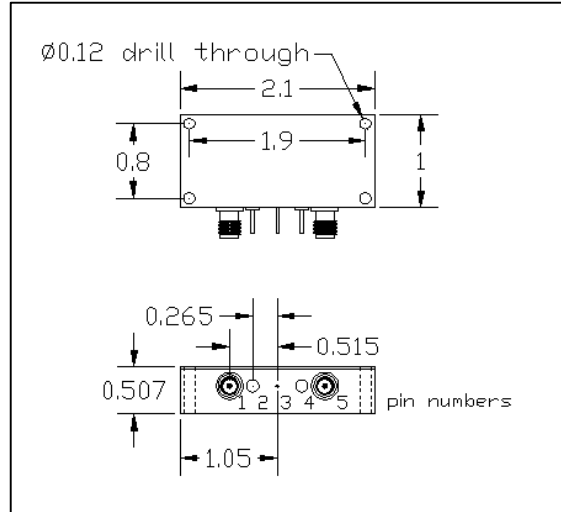

**Absolute Maximum Ratings (T=25 °C)**

Parameter	Symbol	Value	Unit
DC supply Voltage 1	VDD1	32.0	V
DC supply Voltage 2	VDD2		V
AGC Voltage	VAGC	8.00	V
Input Power	Pin	0.05	W
Output Power	Pout	20.0	W
Operating Case Temp.	Tc	-20 to +85	°C
Storage Temperature	Tstg	-30 to +100	°C

**Electrical Characteristics: ( T=25 °C Zs=Zl=50 ohms. Vdd= 28.0 Volts )**

Parameter	Symbol	Min	Typical	Max	Unit	Test Conditions
Frequency Range	BW	30		512	Mhz	50 ohm load
Outut Power	Po	15.0			Watts	Idq = 2.00 Amps
Power Gain	PG	25.0			dB	@ Pout = 15.0 Watts
Total Efficiency	$\eta$	15			%	@ Pout = 15.0 Watts
2nd Harmonics	dso		-20.00		dBc	@ Pout = 15.0 W, Freq = 270 Mhz
Intermod - 2 tone	Ip3				dBm	Freq = 270 Mhz; AvePwr= W
Load Mismatch Tolerance	VSWR	10:1			Relative	All Phase Angles

# MGDQ01

