



Power RF Amplifiers

Power = 10.0 Watts

Bandwidth = 300 to 512 Mhz

Gain = 25.0 dB Vdd =28.0 Volts

50 ohms Input/Output Impedance

Description

The PHM022 is a 12 Watt FM / 4 Watt AM amplifier module covering a bandwidth of 300-512 Mhz. It has a high IP3 rating when operated in the AM mode. This dual stage amplifier is specifically designed for Tetra and Land Mobile UHF band portable radio applications.

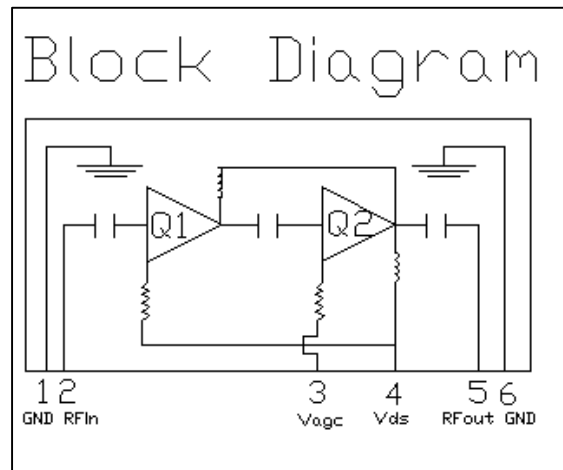
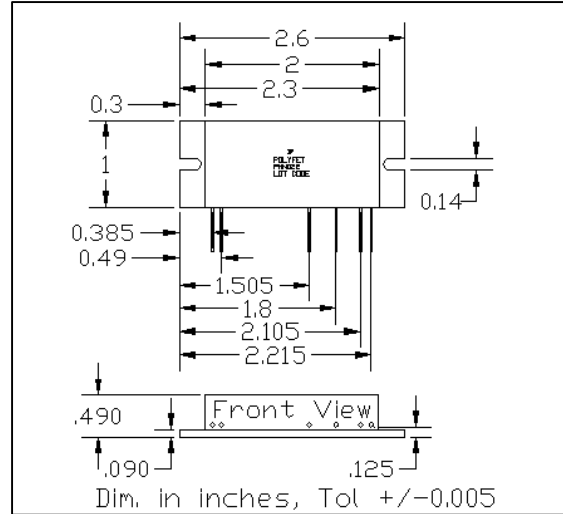

Absolute Maximum Ratings (T=25 °C)

Parameter	Symbol	Value	Unit
DC supply Voltage 1	VDD1	32.0	V
DC supply Voltage 2	VDD2		V
AGC Voltage	VAGC	5.50	V
Input Power	Pin	0.05	W
Output Power	Pout	15.0	W
Operating Case Temp.	Tc	-20 to +70	°C
Storage Temperature	Tstg	-30 to +100	°C

Electrical Characteristics: (T=25 °C Zs=Zl=50 ohms. Vdd= 28.0 Volts)

Parameter	Symbol	Min	Typical	Max	Unit	Test Conditions
Frequency Range	BW	300		512	Mhz	50 ohm load
Outut Power	Po	10.0			Watts	Idq = 1.20 Amps
Power Gain	PG	25.0			dB	@ Pout = 10.0 Watts
Total Efficiency	h	20			%	@ Pout = 10.0 Watts
2nd Harmonics	dso		-20.00		dBc	@ Pout = 10.0 W, Freq = 406 Mhz
Intermod - 2 tone	Ip3	45.00			dBm	Freq = 406 Mhz; AvePwr= 2.0 W
Load Mismatch Tolerance	VSWR	10:1			Relative	All Phase Angles

PHM022

